

HTS (High-speed Transfer Switch) ---HCT Series



I. Overview

High-speed Transfer Switch (HTS) enables fast power transfer (within 5ms) in dual power supply systems (grid-to-grid). It operates at AC 50Hz, with a rated insulation voltage of 1000V, working voltage up to 400V, and current range from 32A to 800A. When one power source fails, it ensures uninterrupted power supply to critical loads such as fire protection.

HTS is ideal for applications requiring high power reliability, including fire systems, high-rise buildings, offices, hotels, malls, hospitals, transportation hubs, telecom, mining, chemical, ships, military, and industrial facilities.

Compliant with **GB/T 14048.11-2016** and **IEC 60947-6-1:2013** standards.

II. Product Features

Comparison: High-speed Transfer Switch (HTS) vs Static Transfer Switch (STS) vs Traditional Automatic Transfer Switch (ATS)

	ATS (Automatic Transfer Switch)	HTS (High-speed Transfer Switch)	STS (Static Transfer Switch)
Definition (Working Principle)	Mechanically operated switch that transfers load between power sources. Typical transfer time exceeds 100 ms, which may cause brief power interruption.	Using FPGA high-speed sampling, vacuum arc extinction, and fast contact technology, this mechanical switch transfers power between two sources within 5 ms, ensuring uninterrupted operation.	A contactless electronic switch device that enables fast transfer between two independent power sources, with the switching unit composed of two mutually controlled thyristors (SCRs).
Standards	GB/T14048.11 (IEC60947-6-1)	GB/T14048.11 (IEC609476)	GB/T34940.1/2/3
Transfer Time	Transfer time on power loss > 100 ms	Transfer time on power loss < 5 ms.	Transfer time on power loss: 4 to 10 ms
Availability of Manual Operating Handle	Manual operating handle is available, allowing manual operation in emergencies	Manual operating handle is available, allowing manual operation in emergencies.	Not available
Resistance to Harmonic Interference	Excellent immunity to harmonic interference	Excellent immunity to harmonic interference.	Weak immunity to harmonic interference.
Surge Withstand Capability (Lightning Protection)	Excellent	Excellent	Very fragile
Overload Capacity	Excellent	Excellent	Overload current: 1.25× rated. For inductive loads, capacity should be 3-5 times larger.
Load Category	Motor/Mixed Load: Up to 10× inrush and breaking current.	Motor/Mixed Load: Up to 6× making and breaking current.	IT / Resistive Load
Availability of Arc Extinguishing System	Air arc extinguishing	Features a vacuum arc extinguishing system for fast arc suppression.	Not available
Product Structure	SPDT or DPST structure, with single-phase motor or excitation drive.	Electromagnetic (excitation) operation, Mechanical latching, Vacuum arc extinguishing	Simple dual thyristor (SCR) arrangement.
Environmental Requirements	No Limitations	No Limitations	Requires precision air conditioning or fan-based cooling.
Energy consumption	No Consumption	No Consumption	High energy consumption: A 400A model typically consumes around 48 kilowatt-hours per day.
Cost	Relatively low	Moderate cost	Higher cost

III. Classification Introduction

3.1 Classification by Main Contact Position

- a) Two-position

(The main contact has two fixed positions, allowing switching between two power sources)

3.2 Classification by Programmable Transfer Mode

3 modes available to choose:

- a) Automatic Transfer with Auto Re-transfer, or b) Automatic Transfer without Auto Re-transfer or c) Mutual Backup

3.3 Classification by poles

- a) 2 poles
- b) 3 poles
- C) 4 poles

IV. Model Designation and Description

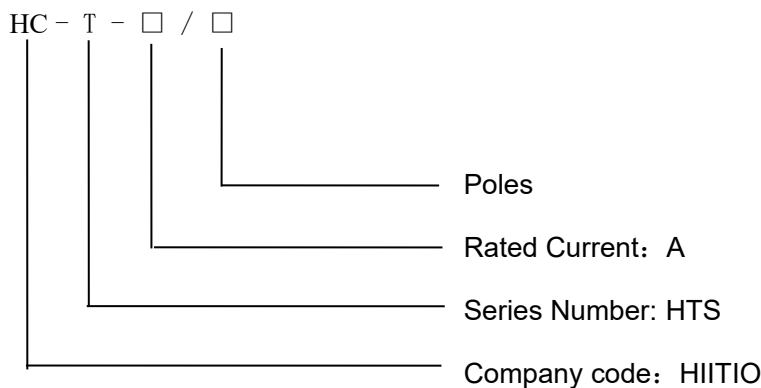

V. Normal operating and installation conditions

5.1 Normal operating conditions

5.1.1 Ambient air temperature

The ambient air temperature shall not exceed +40°C, shall not be lower than -5°C, and the average temperature over a 24-hour period shall not exceed +35°C.

5.1.2 Altitude

The installation site altitude shall not exceed 2000 meters.

5.1.3 Atmospheric conditions

The air shall be clean and free from significant pollution. At a maximum temperature of +40°C, the relative humidity shall not exceed 50%. Higher relative humidity is permissible at lower temperatures, for example, up to 90% at +20°C. Special precautions shall be taken against condensation that may occasionally occur due to temperature variations.

Do not use or store the product in environments containing sulfurized gases, ammonium sulfate gases, or other corrosive gases.

5.1.3.1 Storage temperature

Storage temperature shall be within the range of -20°C to +60°C.

5.1.3.2 Pollution degree

Pollution Degree 3

5.2 Special operating environment

In special environments where the ambient temperature exceeds +40°C or is below -5°C, the altitude is above 2000 meters, or the atmospheric conditions are more severe (beyond the ranges specified above), we can provide customized products based on the user's actual working conditions to meet their requirements.

5.3 Installation category

Installation Category III, suitable for electromagnetic environment B.

VI. Main technical parameters

Model	HCT Series of High-speed Transfer Switch			
Rated Operating Voltage Ue	AC 400V			
Frame Current	125A	200A	400A	800A
Rated operating Current Ie	32A/63A/ 100A/125A	160A/200A	315A/400A	630A/800A
Transfer time	5ms			
Poles	2P/3P/4P			
Electrical level	Class PC			

Utilization Category	Synchronous Transfer – Utilization Category AC-33iB/ Asynchronous (or Out-of-phase) Transfer – Utilization Category AC-31A	
Rated Frequency	50/60 Hz	
Rated Insulation Voltage (Ui)	AC 1000V	
Rated Short-time Withstand Current (Icw)	16kA/1s	
Rated Impulse Withstand Voltage (Uimp)	12kV	
Lifespan	Mechanical	20,000 ops
	Electrical	10,000 ops
Standards	GB/T 14048.11-2016	
Cutout Dimensions for Controller	268*190mm	

VII. Overall Dimensions and Mounting Dimensions (Unit: mm)

7.1 Product Overall and Mounting Dimensions

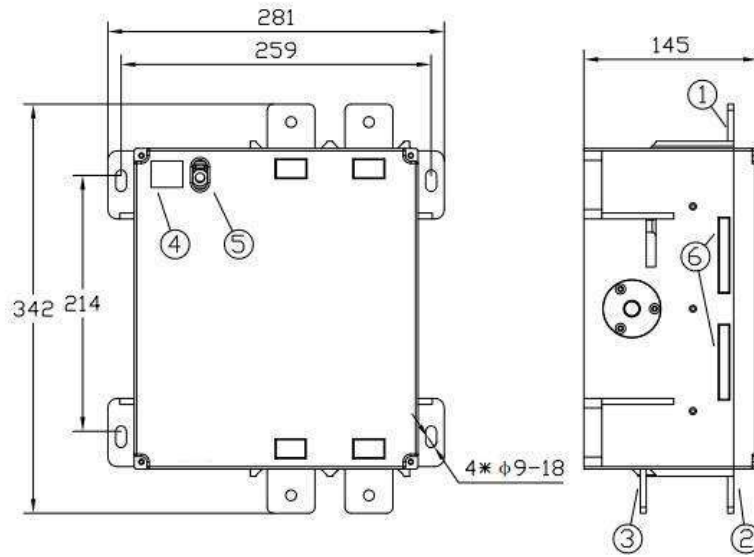

1 Main Power Busbar; 2 Backup Power Busbar;
3 Load Busbar;

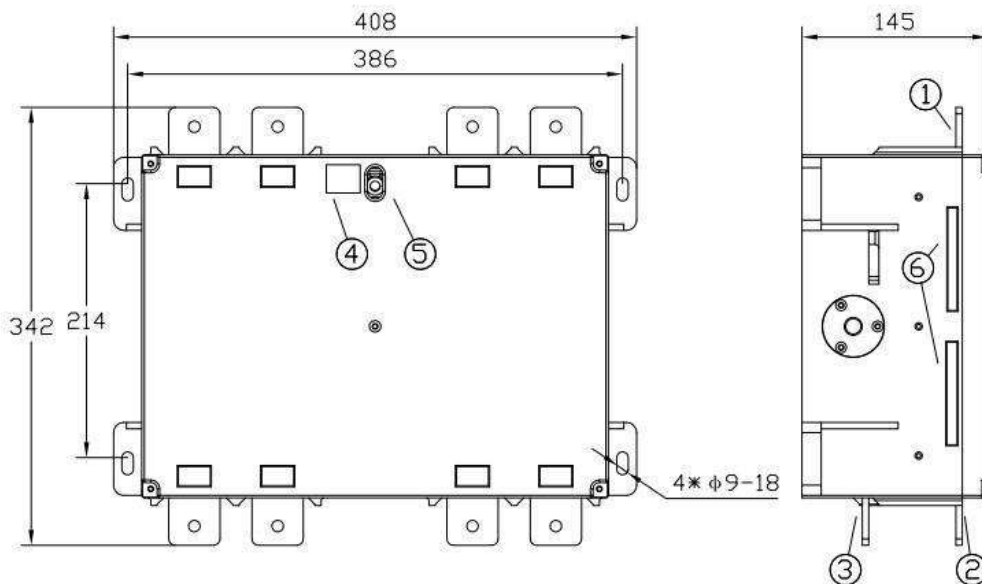

4 Switch Position Display; 5 Operating Handle Hole;
6 Wiring Terminal .

7.2 Controller Cutout Dimensions (Unit: mm)

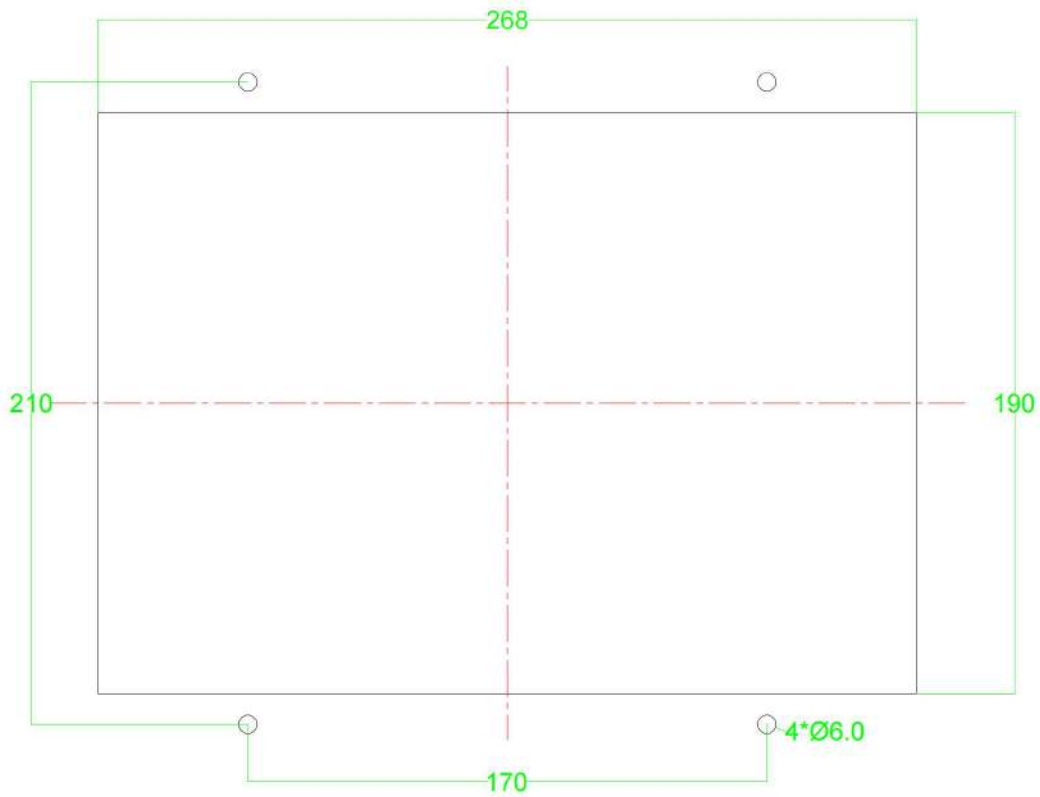

Note: The controller cabinet internal depth is 170 mm.

VIII. Wiring Method and Instructions for the Controller

8.1 Wiring Method of Four-Pole Switch

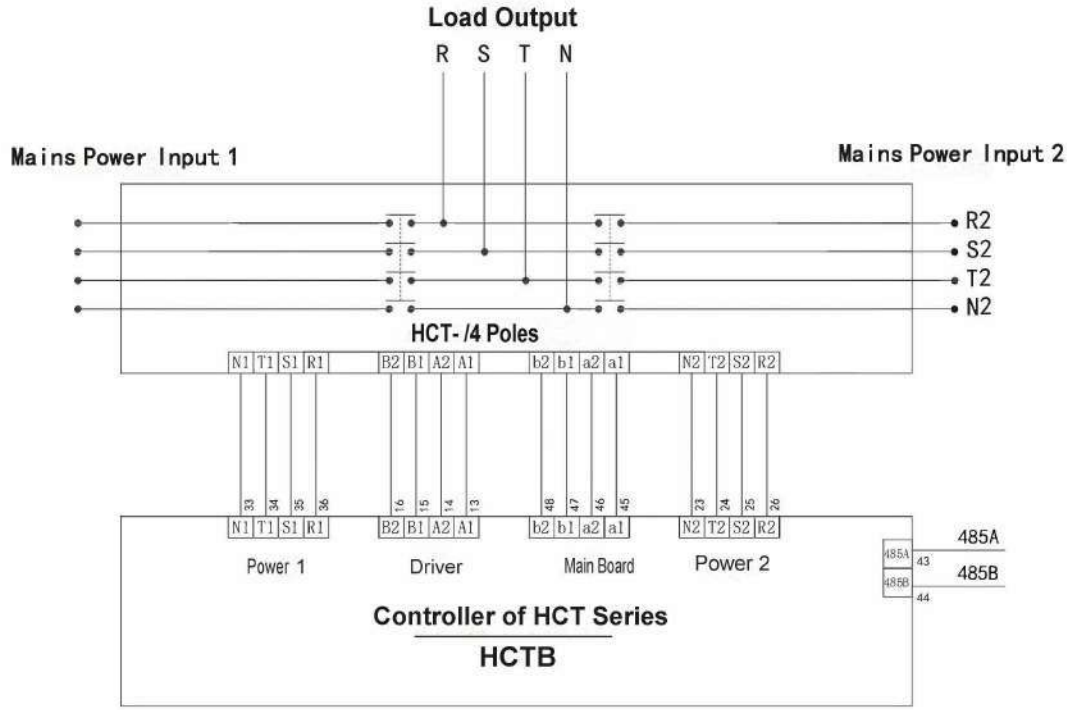

Wiring Terminal of HCT Series			
R1, S1, T1, N1	Power 1 Sampling Terminal	R2, S2, T2, N2	Power 2 Sampling Terminal
A1, A2, B1, B2	Switch Driving Terminal	a1, a2, b1, b2	Switch Position Feedback Terminal

Note:

- (1) The wiring connected to the secondary terminals shall be no less than 1.5 mm².
- (2) Before officially powering on, be sure to confirm that the phases of the main power supply and the backup power supply are consistent!

8.2 Wiring Method of Two-Pole Switch

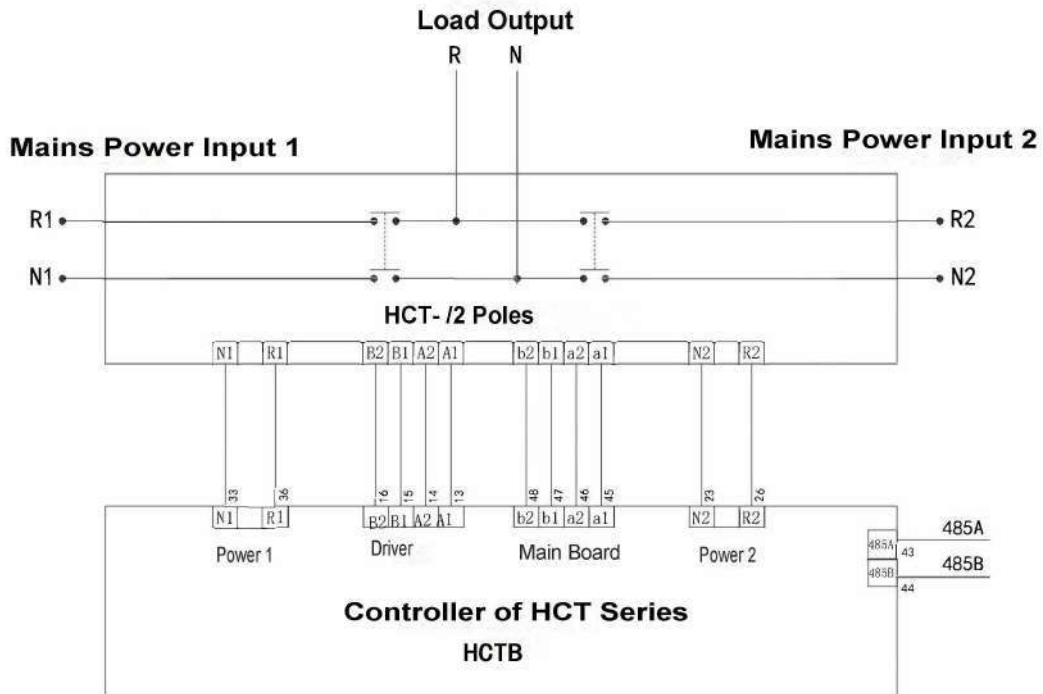

Wiring Terminal of HCT Series			
R1, N1	Power 1 Sampling Terminal	R2, N2	Power 2 Sampling Terminal
A1, A2, B1, B2	Switch Driving Terminal	a1, a2, b1, b2	Switch Position Feedback Terminal

Note:

- (1) The wiring connected to the secondary terminals shall be no less than 1.5 mm².
- (2) Before officially powering on, be sure to confirm that the phases of the main power supply and the backup power supply are consistent!

IX. Manual Operation Method of the Switch

Step 1: Set the dual power controller to manual mode.

Step 2: Insert the handle into the handle operation hole.

Step 3: Move the handle up and down to switch between the main power supply and the backup power supply.

Step 4: Confirm the switch position at this time.

Warning: Do not operate manually when the switch is energized!

Note: After operation, please remove the handle and store it properly.

X. Unboxing Inspection and Authenticity Verification

Upon receipt, check the outer packaging for damage before opening. Verify the items inside against the packing list. Inspect the product for any transport or storage damage. If issues are found, do not use the product and contact the supplier immediately.

XI. Warranty Period and After-Sales Service

This product is manufactured under a comprehensive quality management system and complies with relevant national standards. In the event of a product malfunction, the following warranty and after-sales service terms apply:

Our company provides a 12-month warranty period for this product. During the warranty period, if damage or malfunction occurs due to product quality issues, we will offer free repair or replacement.

However, faults caused by the following reasons will be subject to chargeable repair or replacement, even within the warranty period:

- a) Incorrect use, unauthorized modifications, or improper repairs;
- b) Usage beyond standard specifications;
- c) Damage caused by user mishandling, dropping, or during installation;
- d) Natural disasters such as earthquakes, fires, lightning strikes, abnormal voltage, or secondary disasters.