

HCS05FH230E2B2

2300V/5mΩ Half Bridge SiC MOSFET Module

The HCS05FH230E2B2 is a power module containing 5 mΩ /2300V SiC MOSFET half-bridge and a thermistor with Si₃N₄ AMB in a B2 package.

Features

- 5mΩ / 2300 V SiC MOSFET Half-Bridge
- Si₃N₄ NAMB
- NTC Thermistor
- Low Inductive Layout
- Solderable Pins
- Isolated Base Plate

Typical Applications

- Motor Drives
- Vehicle Fast Chargers
- Renewable energy
- Uninterruptible Power Supply Systems (UPS)

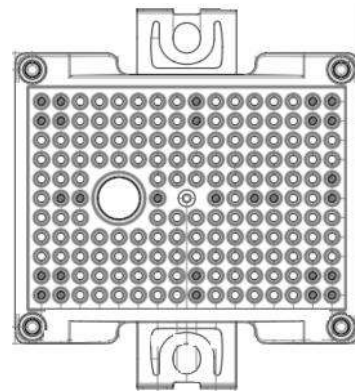

PIM7, 106.10 × 61.00 × 30.85

MARKING DIAGRAM

PIN ASSIGNMENTS

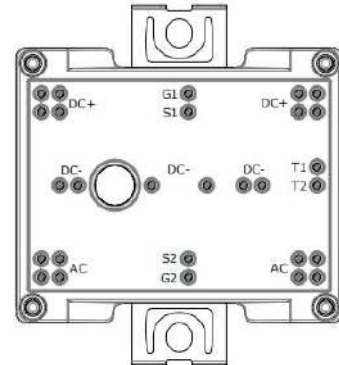

ORDERING INFORMATION

Device	Package
HCS05FH230E2B2	Easy2B

PIN DESCRIPTION

Pin	Name	Description
1	OUT	Center Point of Half Bridge
2	DC-	DC Negative Bus Connection
3	DC+	DC Positive Bus Connection
4	G1	T1 Gate
5	S1	T1 Source
6	G2	T2 Gate
7	S2	T2 Source

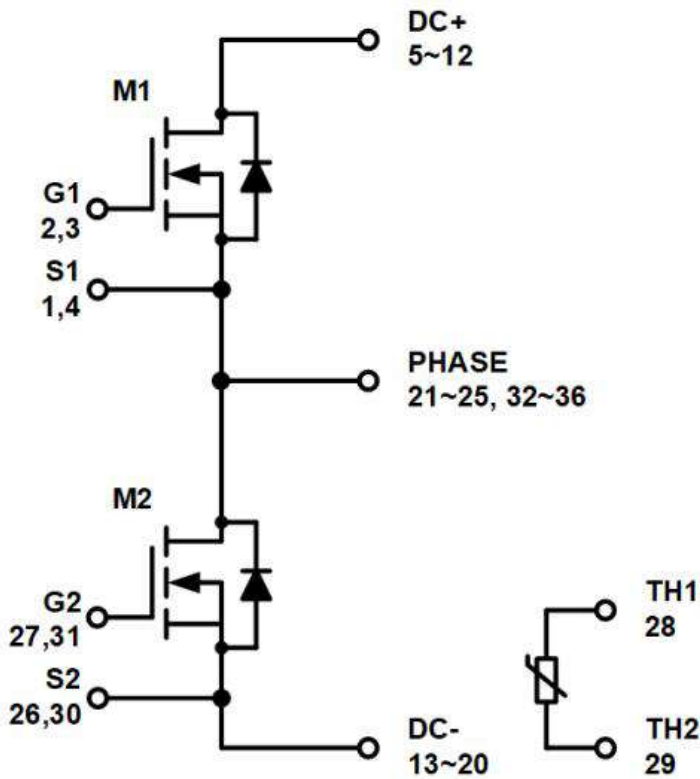

Schematic

MAXIMUM RATINGS

Rating	Symbol	Value	Unit
--------	--------	-------	------

SIC MOSFET

Drain-Source Voltage	V_{DS}	2300	V
Gate-Source Voltage	V_{GS}	+22/-10	V
Continuous Drain Current @ $T_c = 80^\circ\text{C}$ ($T_j = 175^\circ\text{C}$)	I_{DS}	240	A
Pulsed Drain Current ($T_j = 175^\circ\text{C}$)	I_{DPulse}	300	A
Maximum Power Dissipation @ $T_c = 80^\circ\text{C}$ ($T_j = 175^\circ\text{C}$)	P_{tot}	710	W
Minimum Operating Junction Temperature	T_{JMIN}	-40	$^\circ\text{C}$
Maximum Operating Junction Temperature	T_{JMAX}	175	$^\circ\text{C}$

ELECTRICAL CHARACTERISTICS ($T_j = 25^\circ\text{C}$ unless otherwise noted)

Parameter	Test Conditions	Symbol	Min	Typ	Max	Unit
-----------	-----------------	--------	-----	-----	-----	------

SIC MOSFET CHARACTERISTICS

Zero Gate Voltage Drain Current	$V_{GS} = 0\text{V}, V_{DS} = 1200\text{V}$	I_{DSS}	-	-	1	mA
Drain-Source On Resistance	$V_{GS} = 18\text{V}, I_{DS} = 240\text{A}, T_j = 25^\circ\text{C}$	$R_{DS(on)}$	-	5	7	m Ω
	$V_{GS} = 18\text{V}, I_{DS} = 240\text{A}, T_j = 125^\circ\text{C}$		-	10	-	
	$V_{GS} = 18\text{V}, I_{DS} = 240\text{A}, T_j = 150^\circ\text{C}$		-	11	-	
Gate-Source Threshold Voltage	$V_{GS} = V_{DS}, I_{DS} = 148\text{mA}$	$V_{GS(TH)}$	-	2.8		V
Gate Resistance	$V_{GS} = 0\text{V}, f = 1\text{MHz}$	R_g	-	1.5	-	ohm
Gate Leakage Current	$V_{GS} = -10\text{V} / 20\text{V}, V_{DS} = 0\text{V}$	I_{GSS}	-800	-	+800	nA
Input Capacitance	$V_{DS} = 1500\text{V}, V_{GS} = 0\text{V}, f = 100\text{kHz}$	C_{iss}	-	25.1	-	nF
Reverse Transfer Capacitance		C_{rss}	-	50	-	pF
Output Capacitance		C_{oss}	-	600	-	pF

ELECTRICAL CHARACTERISTICS ($T_j = 25^\circ\text{C}$ unless otherwise noted) (continued)

Parameter	Test Conditions	Symbol	Min	Typ	Max	Unit
-----------	-----------------	--------	-----	-----	-----	------

SIC MOSFET CHARACTERISTICS

Total Gate Charge	$V_{DS} = 1500\text{V}, V_{GS} = -5/20\text{V}, I_D = 240\text{A}$	$Q_{G(TOTAL)}$	-	0.88	-	μC	
Gate-Source Charge		Q_{GS}	-	0.54	-	nC	
Gate-Drain Charge		Q_{GD}	-	0.13	-	nC	
Turn-on Delay Time	$V_{DS} = 1200\text{V}, I_{DS} = 200\text{A}, V_{GS} = -3/18\text{V}, R_G = 7.5\Omega$	$T_j = 25^\circ\text{C}$	$T_{d(on)}$	-	82.1	-	ns
		$T_j = 125^\circ\text{C}$		-	73.3	-	ns
		$T_j = 175^\circ\text{C}$		-	64.5	-	ns
Rise Time		$T_j = 25^\circ\text{C}$	t_r	-	156.1	-	ns
		$T_j = 125^\circ\text{C}$		-	123.8	-	ns
		$T_j = 175^\circ\text{C}$		-	140.4	-	ns
Turn-off Delay Time	$V_{DS} = 1200\text{V}, I_{DS} = 200\text{A}, V_{GS} = -3/18\text{V}, R_G = 4.7\Omega$	$T_j = 25^\circ\text{C}$	$T_{d(off)}$	-	217.4	-	ns
		$T_j = 125^\circ\text{C}$		-	265.3	-	ns
		$T_j = 175^\circ\text{C}$		-	234.7	-	ns
Fall Time		$T_j = 25^\circ\text{C}$	t_f	-	153.2	-	ns
		$T_j = 125^\circ\text{C}$		-	152.4	-	ns
		$T_j = 175^\circ\text{C}$		-	163.1	-	ns
Turn-on Switching Loss per Pulse	$V_{DS} = 1200\text{V}, I_{DS} = 200\text{A}, V_{GS} = -3/18\text{V}, R_G = 7.5\Omega$	$T_j = 25^\circ\text{C}$	E_{on}	-	4.2	-	mJ
		$T_j = 125^\circ\text{C}$		-	3.5	-	mJ
		$T_j = 175^\circ\text{C}$		-	7.7	-	mJ
Turn-off Switching Loss per Pulse		$T_j = 25^\circ\text{C}$	E_{off}	-	2.3	-	mJ
		$T_j = 125^\circ\text{C}$		-	2.6	-	mJ
		$T_j = 175^\circ\text{C}$		-	5.6	-	mJ

ELECTRICAL CHARACTERISTICS ($T_J = 25^\circ\text{C}$ unless otherwise noted) (continued)

Parameter	Test Conditions	Symbol	Min	Typ	Max	Unit
-----------	-----------------	--------	-----	-----	-----	------

SiC MOSFET CHARACTERISTICS

Diode Forward Voltage	$I_{SD} = 200\text{A}, T_J = 25^\circ\text{C}$	V_{SD}	-	4.37	4.67	V
	$I_{SD} = 200\text{A}, T_J = 125^\circ\text{C}$		-	4.06	-	
	$I_{SD} = 200\text{A}, T_J = 150^\circ\text{C}$		-	4.01	-	
Diode Reverse Recovery Charge	$V_R = 1200\text{V}, I_{SD} = 200\text{A}$	Q_r	-	10.2	-	μC
Peak Reverse Recovery Current	$V_{GS} = -5\text{V}, R_G = 4.7\Omega$ $T_J = 25^\circ\text{C}$	I_{rrm}	-	289.4	-	A
Reverse Recovery Energy		E_{rr}	-	0.13	-	mJ
Diode Reverse Recovery Charge	$V_R = 1200\text{V}, I_{SD} = 200\text{A}$	Q_r	-	13.6	-	μC
Peak Reverse Recovery Current	$V_{GS} = -5\text{V}, R_G = 4.7\Omega$ $T_J = 125^\circ\text{C}$	I_{rrm}	-	306.8	-	A
Reverse Recovery Energy		E_{rr}	-	0.89	-	mJ
Diode Reverse Recovery Charge	$V_R = 1200\text{V}, I_{SD} = 200\text{A}$	Q_r	-	14.3	-	μC
Peak Reverse Recovery Current	$V_{GS} = -5\text{V}, R_G = 4.7\Omega$ $T_J = 150^\circ\text{C}$	I_{rrm}	-	324.4	-	A
Reverse Recovery Energy		E_{rr}	-	3.1	-	mJ
Thermal Resistance – Chip-to-Case	M1, M2	R_{thJC}	-	0.701	-	$^\circ\text{C}/\text{W}$
Thermal Resistance – Chip-to-Heatsink	Thermal grease, Thickness = 2 Mil +2%, A = 2.8 W/mK	R_{thJH}	-	0.323	-	$^\circ\text{C}/\text{W}$

THERMISTOR CHARACTERISTICS

Rated Resistance		R_{25}	-	5.0	-	$\text{K}\Omega$
Deviation of R_{100}	$T_C = 100^\circ\text{C}, R_{100} = 493.3\Omega$	$\Delta R/R$	-5	-	5	%
Power Dissipation		P_{25}	-	-	10	mW
B-value	$R_2 = R_{25} \exp[B_{25/50}(1/T_2 - 1/(298.15\text{K}))]$	$B_{25/50}$	-	3375	-	K
B-value	$R_2 = R_{25} \exp[B_{25/80}(1/T_2 - 1/(298.15\text{K}))]$	$B_{25/80}$	-	3436	-	K

MODULE

Storage Temperature Range	T_{stg}	-40 to 150	$^\circ\text{C}$
Module Operating Junction Temperature	T_J	-40 to 150	$^\circ\text{C}$
Isolation Test Voltage, $t = 1\text{s}, 50\text{Hz}$	V_{iso}	4000	V_{RMS}
Weight of Module	G	41	g

TYPICAL CHARACTERISTIC

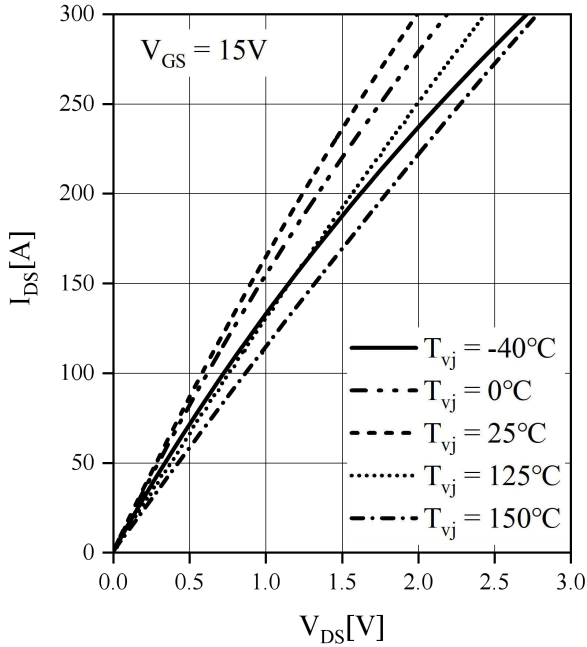

Figure 1. Output Characteristics for Various Junction Temperatures

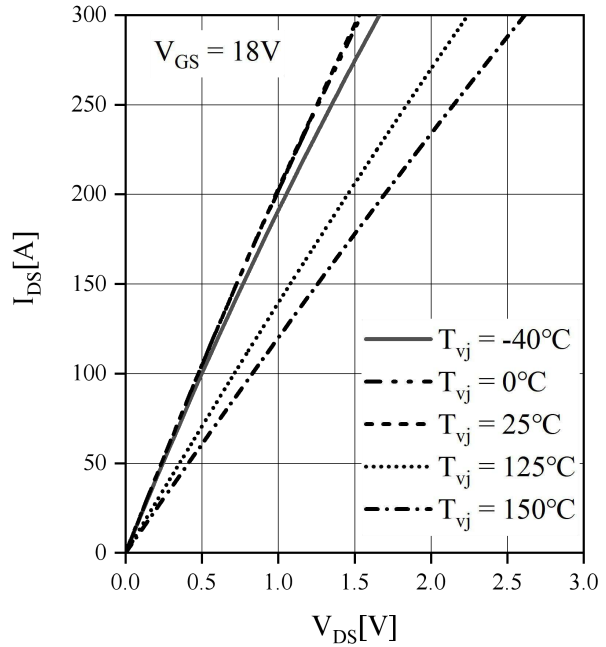

Figure 2. Output Characteristics for Various Junction Temperatures

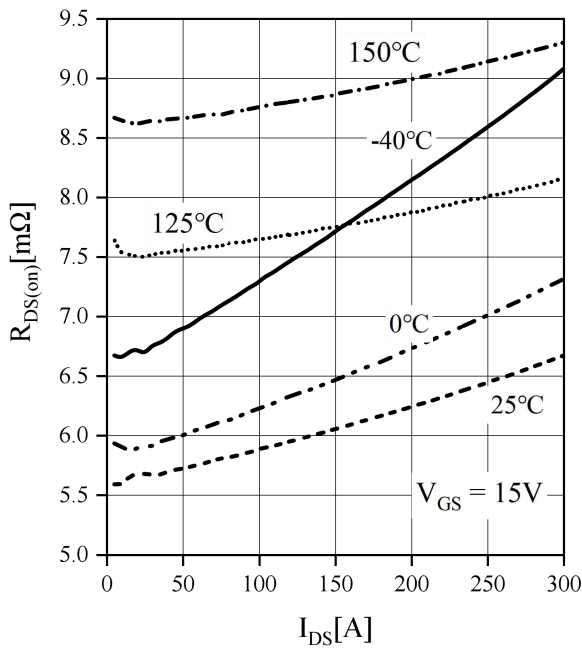

Figure 3. On-State Resistance vs. Drain Current for Various Junction Temperatures

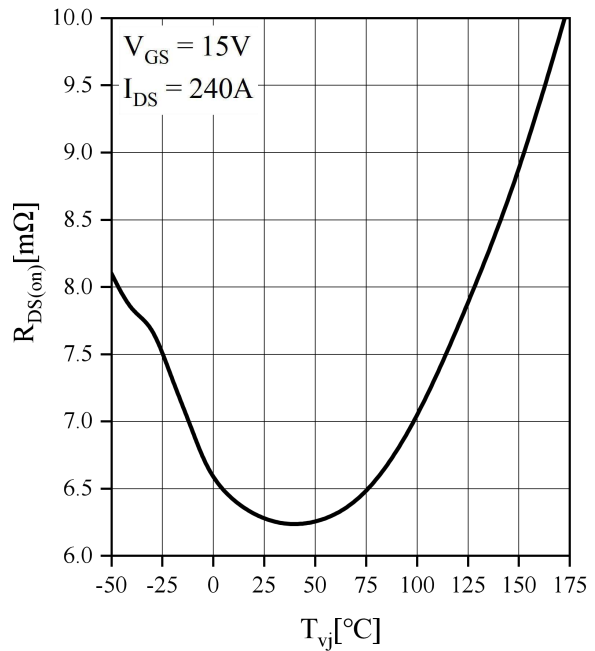

Figure 4. On-State Resistance vs. Junction Temperature

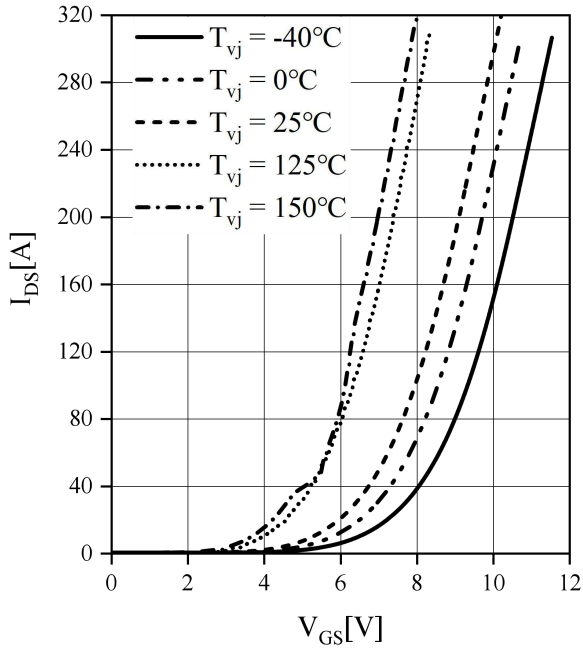

Figure 5. Transfer Characteristic for Various Junction Temperatures

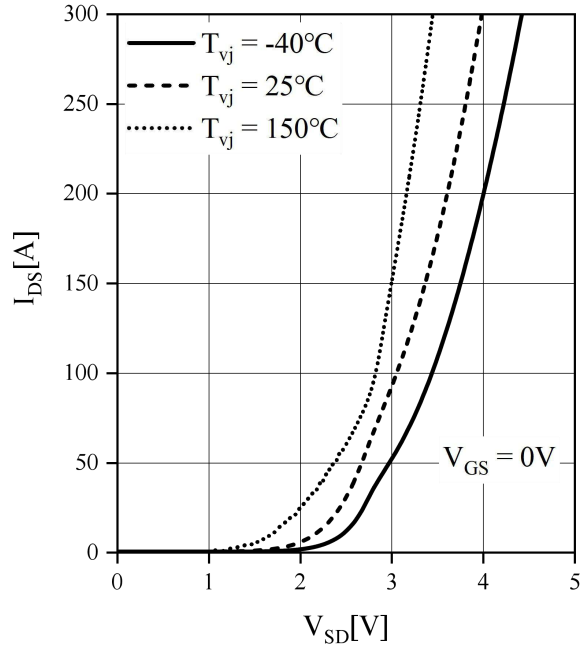

Figure 6. 3rd Quadrant Characteristic vs. Junction Temperatures at V_GS = 0V (Body Diode)

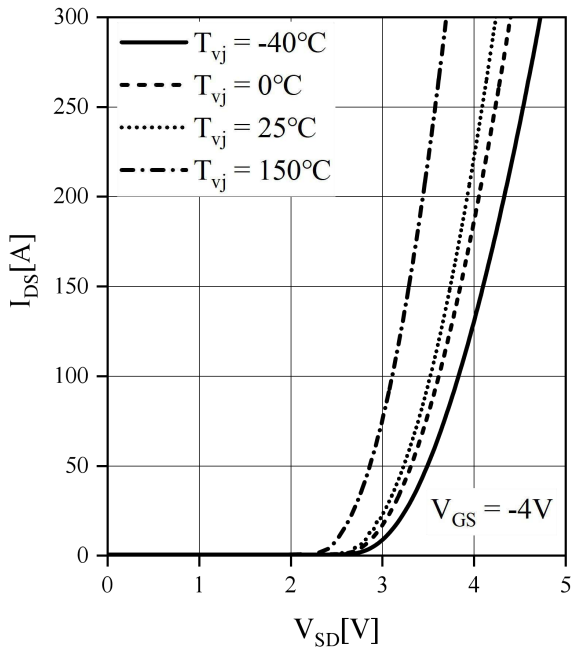

Figure 7. 3rd Quadrant Characteristic vs. Junction Temperatures at V_GS = -4V (Body Diode)

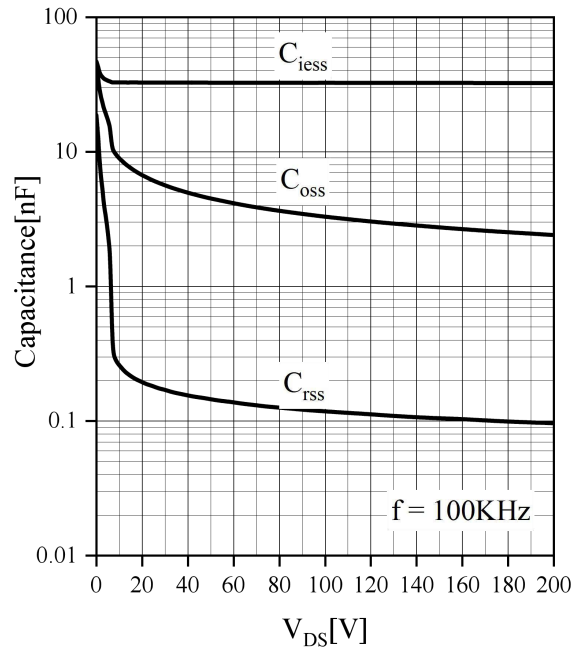

Figure 8. Typical Capacitances vs. Drain to Source Voltage (0 - 200V)

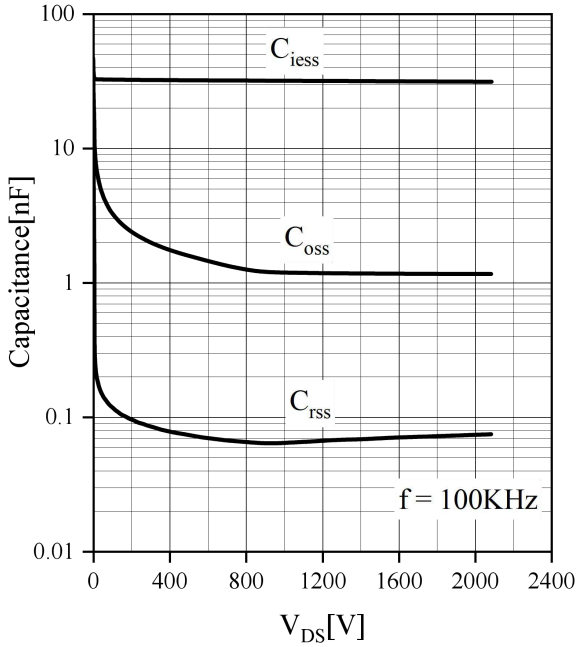

Figure 9. Typical Capacitances vs. Drain to Source Voltage (0 - 2300V)

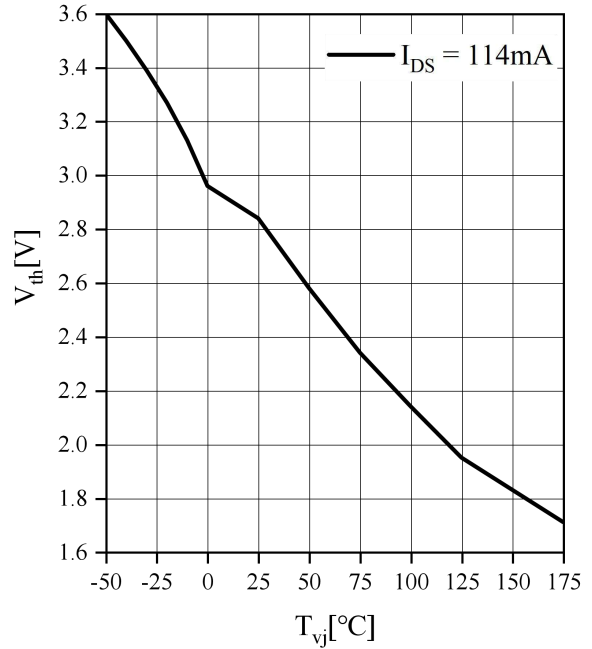

Figure 10. Threshold Voltage vs. Junction Temperature

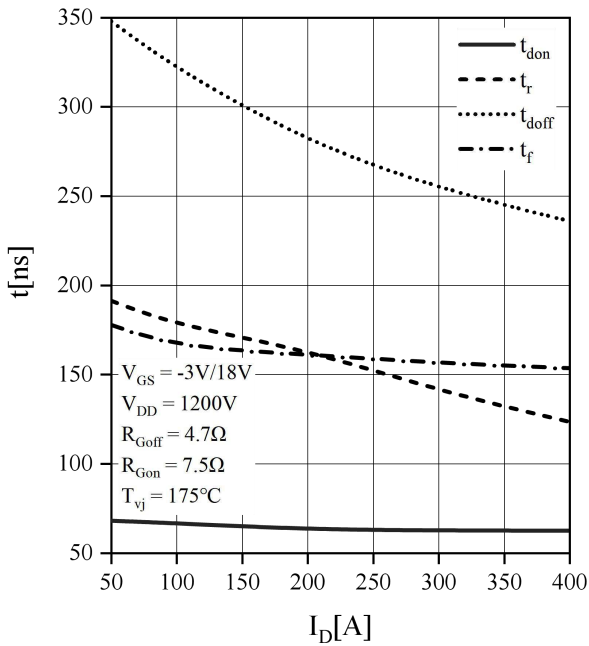

Figure 11. Switching times

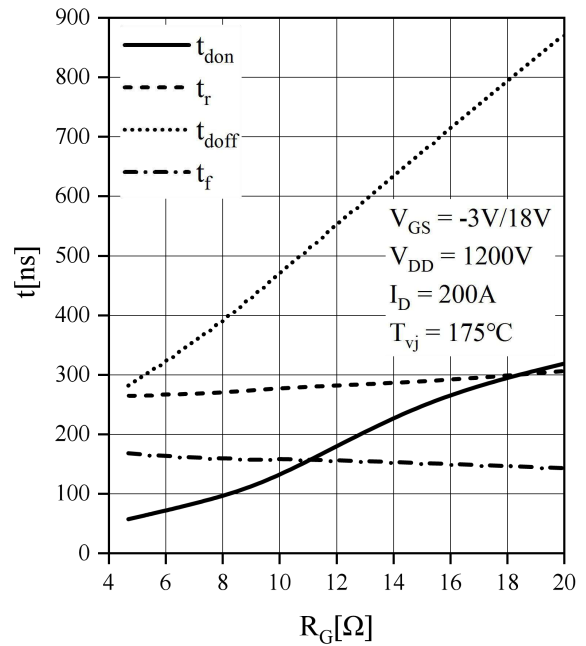

Figure 12. Switching times

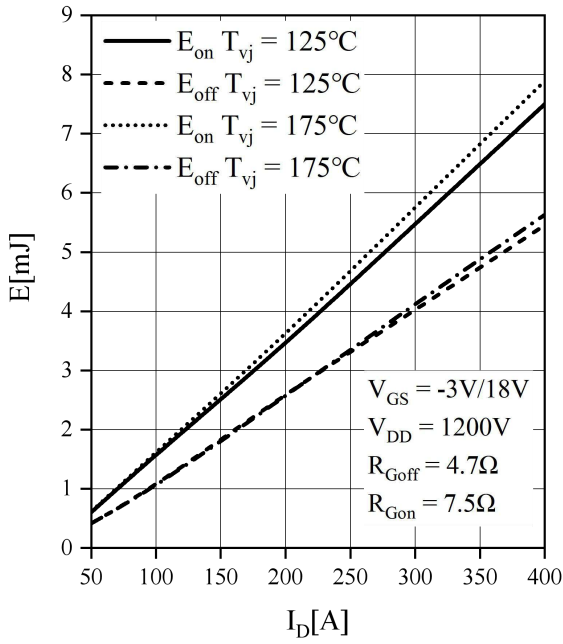

Figure 13. Switching losses

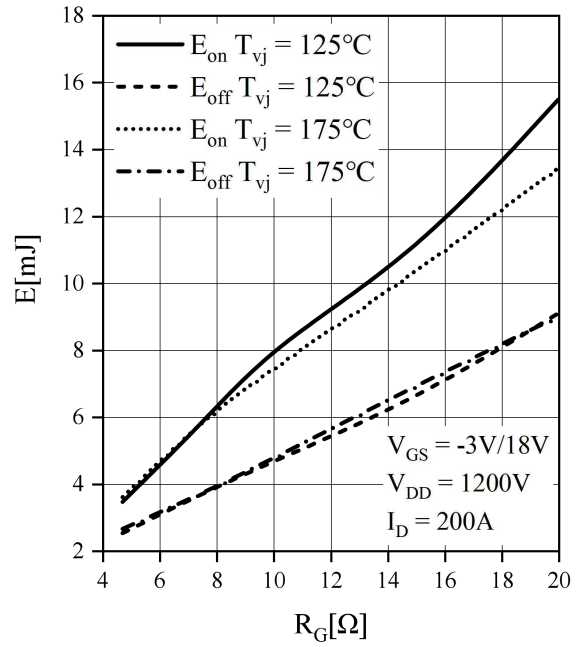

Figure 14. Switching losses

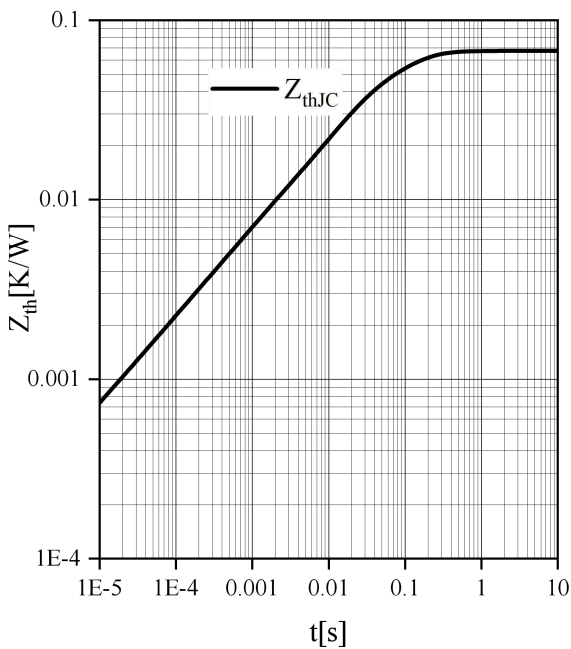

Figure 15. MOSFET Junction to Heatsink Transient Thermal Impedance, $Z_{th\ JHS}$ ($^\circ\text{C}/\text{W}$)

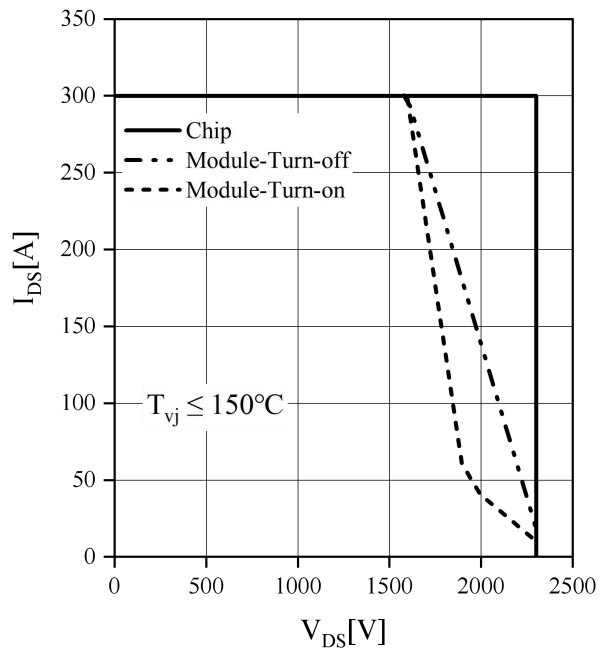

Figure 16. Switching Safe Operating Area

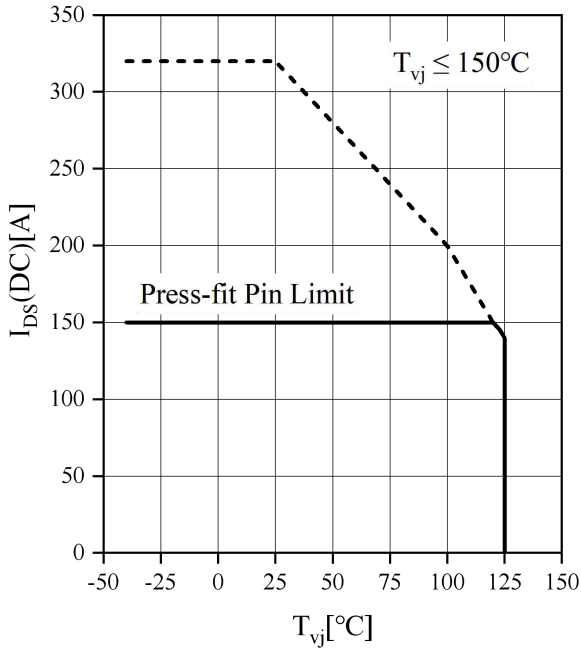

Figure 17. Continuous Drain Current Derating vs. Heatsink Temperature

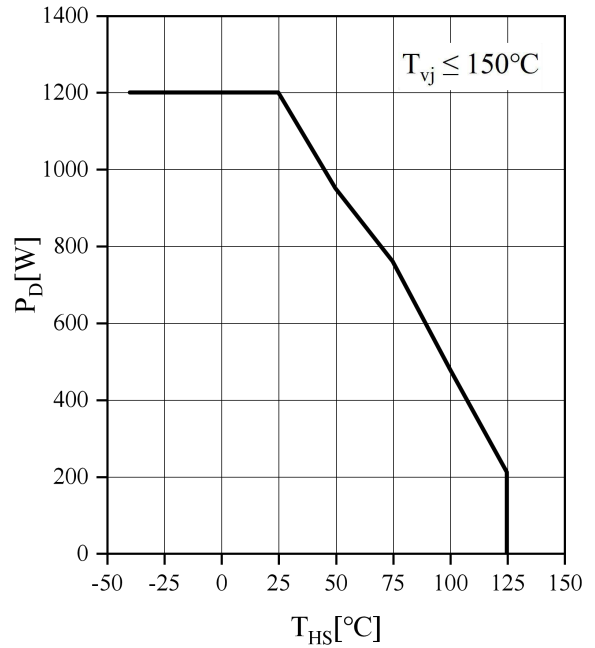

Figure 18. Maximum Power Dissipation Derating vs. Heatsink Temperature

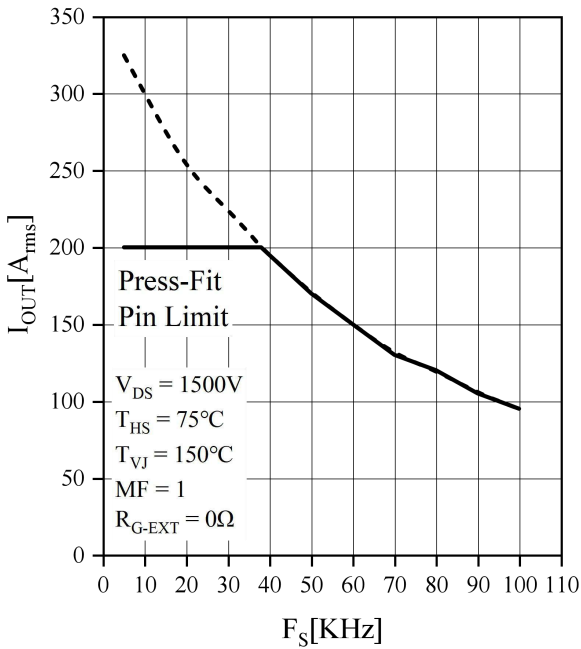

Figure 19. Typical Output Current Capability vs. Switching Frequency (Inverter Application)

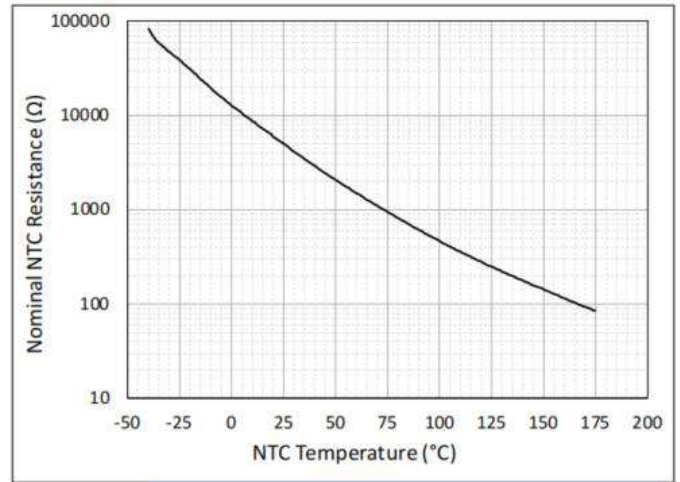
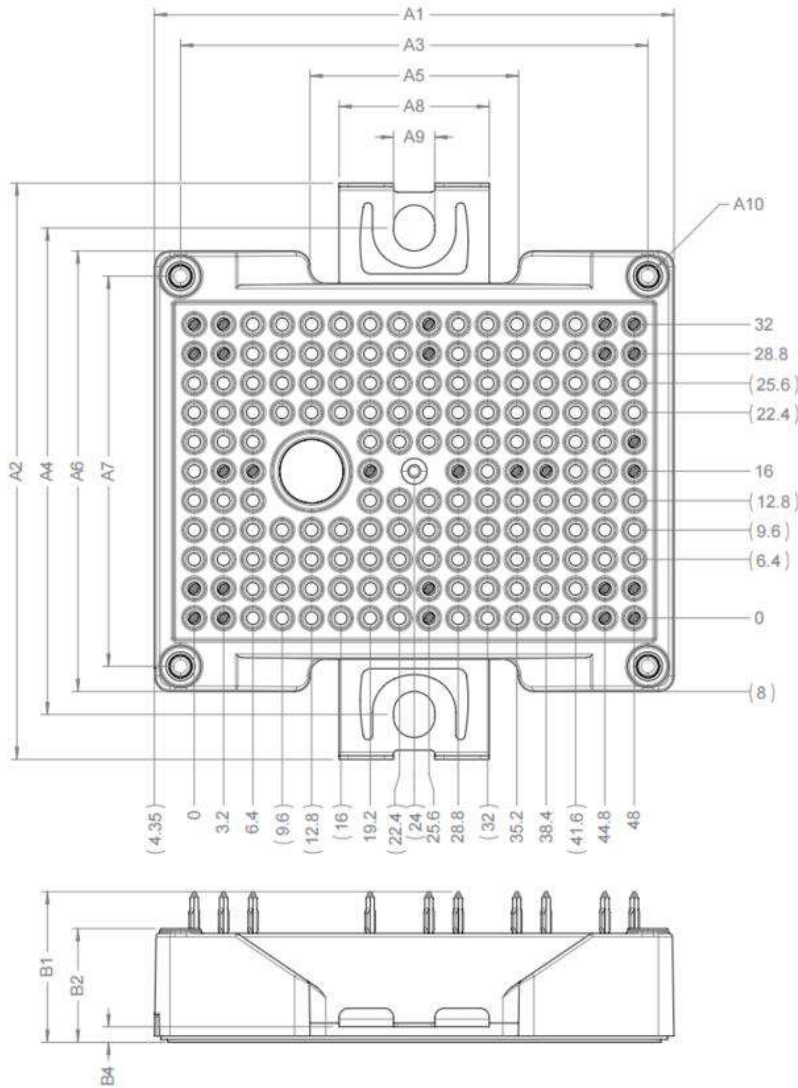

Figure 21. Nominal NTC Resistance vs. NTC Temperature

Package Drawing



DIMENSION TABLE		
SYMBOL	DIMENSION	TOLERANCE
A1	56.7	±0.30
A2	62.8	±0.50
A3	51	±0.15
A4	(53)	REF.
A5	22.7	±0.30
A6	48	±0.30
A7	42.5	±0.15
A8	16.4	±0.20
A9	4.5	±0.10
A10	∅2.3 √8.5	∅: ⁺⁰ / _{-0.10} √: ±0.30
B1	16.4	±0.50
B2	12.33	±0.35
B4	1.8	±0.20
ALL PIN LOCATIONS		±0.40

UNIT:mm