

技术参数 Specifications

电气参数 Ratings:

- ◇最大工作电压
Max. Switching Voltage: 750VDC
- ◇额定电流
Rated Current: 40A
- ◇主触点形式
Main Contact Type: 一组常开 SPST-NO
- ◇辅助触点
Auxiliary Contact: 无 Nil
- ◇辅助触点形式
Auxiliary Contact Type: 无 Nil
- ◇线圈额定电压
Coil Rated Voltage : 12VDC/24VDC
- ◇使用环境温度
Ambient Operation Temperature : -40°C~+85°C
- ◇使用环境湿度
Ambient Operation Humidity : 5%~85%RH

认证/标准 Approvals/Standard:

- ◇REACH
- ◇RoHS



产品特征 Features&Benefits:

- 体积小，重量轻；
Small size, light weight;
- 能够在85°C环境下持续承载40A电流；
Carrying current 40A continuously at 85°C;
- 永磁体灭弧设计，实现零飞弧，保证使用安全性和可靠性；
The permanent magnet arc extinguishing design realizes zero flashover, ensuring the safety and reliability of use;

产品型号说明 Product Model:

	HC	F	40	B/	750	-24	H	Q	3	<input type="checkbox"/>	<input type="checkbox"/>	- ()
公司代码 Company Code												
系列代码 Series Code	F:方形系列 Square Series											
触点容量 (额定电流) Contact Rating(Rated Current)	40:40A											
衍生型号 Derivative Model	B:衍生型 Derivative Model											
负载电压 Load Voltage	450:450VDC; 750:750VDC											
线圈电压 Coil Voltage	12:12VDC; 24:24VDC											
主触点形式 Main Contact Type	H: 一组常开 SPST-NO											
线圈出线方式 Coil Input Terminal	Q: QC引出端 Terminal; P: PCB引出端 Terminal											
负载引出端方式 Load Input Terminal	3: QC引出端 Terminal; 4: PCB引出端 Terminal											
辅助触点 Auxiliary Contact	无 Nil: 无辅助触点 No Auxiliary Contact											
安装形式 Mounting	无 Nil: 立体安装 Vertical Mounting; B: PCB安装 Mounting											
特性号 Special Code	XXX: 客户特殊要求 Customer Special Code; 无 Nil: 标准型 Standard											

HCF40B/□-□HQ3

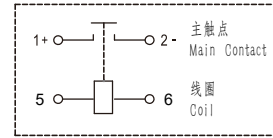
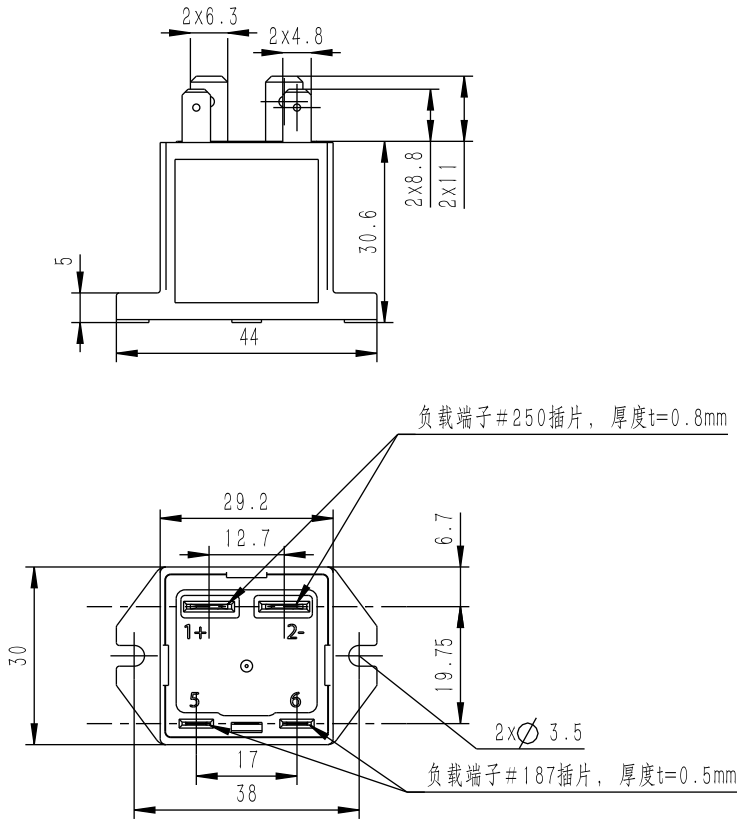

接线图
Coil Wiring Diagram

未注公差 General Tolerance:
 < 10mm: ±0.3mm
 10-50mm: ±0.5mm
 > 50mm: ±0.8mm

特性参数 CHARACTERISTIC PARAMETERS

主触点参数 MAIN CONTACT DATA

最大工作电压 Max. Switching Voltage	750VDC	额定电流 Rated Current	40A
触点形式 Contact Arrangement	一组常开 SPST-NO	触点压降 Contact Voltage Drop	≤0.4V(at 40A)
短时承载电流 Limiting Short-time Current	60A:1800s; 80A:60s; 160A:5s; 240A:3s		
电寿命(阻性负载) Electrical Life (Resistive Load)	450V 型 Model	750V 型 Model	
	10A 450VDC 10000次 (ops); 40A 450VDC 1000次 (ops); 40A 450VDC 75000次 (ops); 仅接通 Only Making		40A 750VDC 50000次 (ops), 仅接通 Only Making

性能参数 CHARACTERISTIC DATA

介质耐压 Dielectric Strength	主触点与线圈间(初始) Between Main Contacts and Coil (Initial)	≥3000VAC(1min)	绝缘电阻 Insulation Resistance	主触点与线圈间(初始) Between Main Contacts and Coil (Initial)	≥1000MΩ(750VDC)
	断开主触点间(初始) Between Open Main Contacts (Initial)	≥2500VAC(1min)		断开主触点间(初始) Between Open Main Contacts (Initial)	≥1000MΩ(750VDC)
耐冲击 Shock Resistance	功能性 Functional	20g 半正弦波 Half-Sine Wave 11ms	耐振动 Vibration Resistance	功能性 Functional	49m/s ² (10~500Hz)
	强度 Destructive	50g 半正弦波 Half-Sine Wave 6ms			
吸合时间 Operate Time	Max:30ms		机械寿命 Mechanical Life	2*10 ⁵ 次(ops)	
释放时间 Release Time	Max:10ms		重量 Weight	约 Approx 55g	

线圈参数 COIL DATA

额定电压 Rated Voltage	12VDC	24VDC
吸合电压 Pick-up Voltage	≤9VDC	≤18VDC
释放电压 Drop-out Voltage	≥1VDC	≥2VDC
线圈功率 Rated Operating Power	约 Approx 3W	约 Approx 3W
最大允许电压 Max. Allowable Voltage	16VDC	32VDC

HCF40B/□-□HP4B

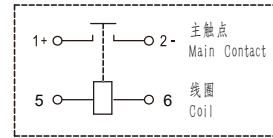
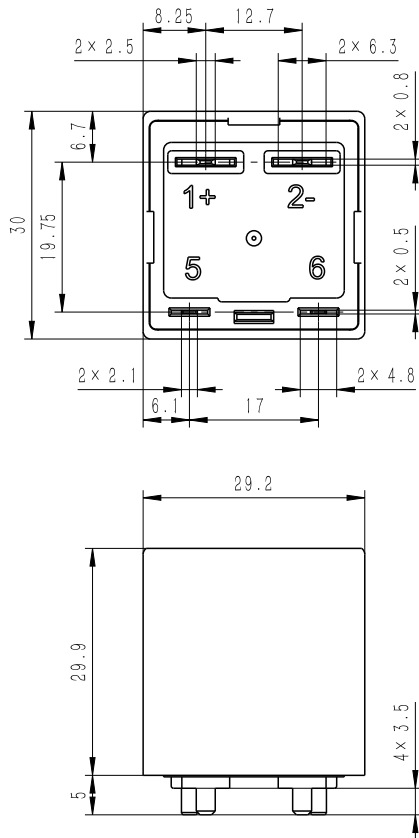

接线图
Coil Wiring Diagram

未注公差 General Tolerance:
 < 10mm: ± 0.3mm
 10~50mm: ± 0.5mm
 > 50mm: ± 0.8mm

特性参数 CHARACTERISTIC PARAMETERS			
主触点参数 MAIN CONTACT DATA			
最大工作电压 Max. Switching Voltage	450VDC	额定电流 Rated Current	40A
触点形式 Contact Arrangement	一组常开 SPST-NO	触点压降 Contact Voltage Drop	≤0.4(at 40A)
短时承载电流 Limiting Short-time Current	60A:1800s; 80A:60s; 160A:5s; 240A:3s		
电寿命 (阻性负载) Electrical Life (Resistive Load)	450V 型 Model 10A 450VDC 10000次 (ops); 40A 450VDC 1000次 (ops); 40A 450VDC 75000次 (ops), 仅接通 Only Making		750V 型 Model 40A 750VDC 50000次 (ops), 仅接通 Only Making
性能参数 CHARACTERISTIC DATA			
介质耐压 Dielectric Strength	主触点与线圈间(初始) Between Main Contacts and Coil (Initial)	≥3000VAC(1min)	绝缘电阻 Insulation Resistance
	断开主触点间(初始) Between Open Main Contacts (Initial)	≥2500VAC(1min)	
耐冲击 Shock Resistance	功能性 Functional	20g 半正弦波 Half-Sine Wave 11ms	耐振动 Vibration Resistance
	强度 Destructive	50g 半正弦波 Half-Sine Wave 6ms	
吸合时间 Operate Time	Max:30ms	机械寿命 Mechanical Life	2*10 ⁵ 次(ops)
释放时间 Release Time	Max:10ms	重量 Weight	约 Approx 55g
线圈参数 COIL DATA			
额定电压 Rated Voltage	12VDC		24VDC
吸合电压 Pick-up Voltage	≤9VDC		≤18VDC
释放电压 Drop-out Voltage	≥1VDC		≥2VDC
线圈功率 Rated Operating Power	约 Approx 3W		约 Approx 3W
最大允许电压 Max. Allowable Voltage	16VDC		32VDC

电流承载曲线 Current Carry Curve:

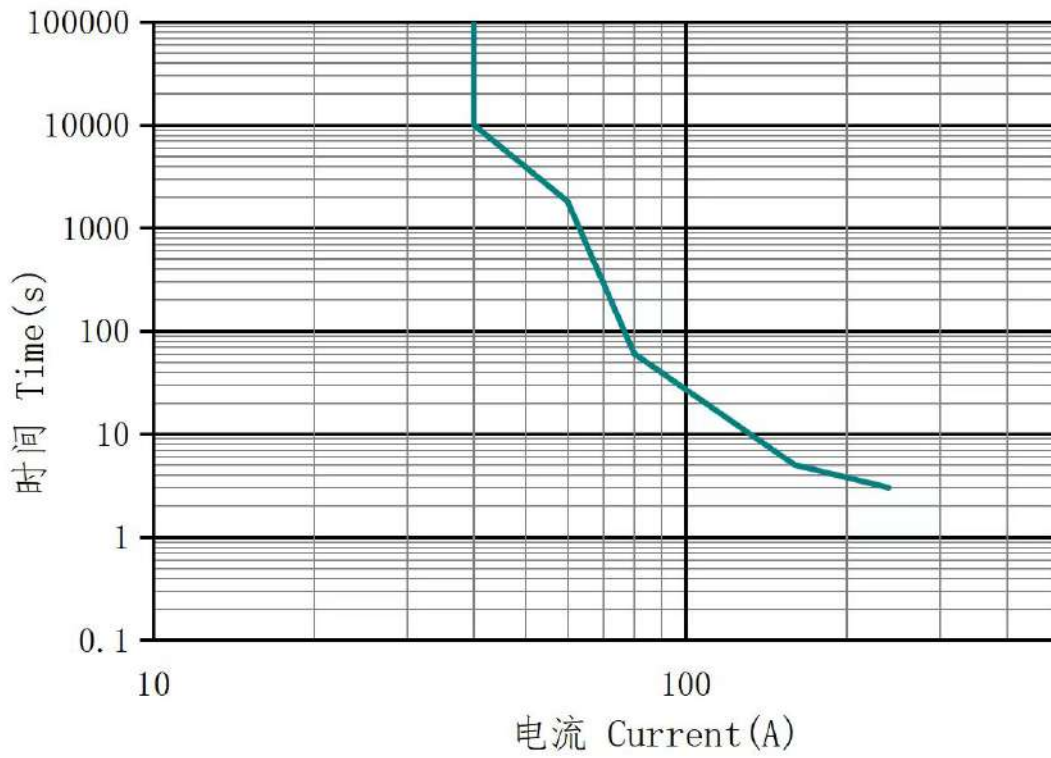

使用注意事项 Caution:

- 规格书内的各项性能参数是基于标准测试条件下测得的初始值。
All the performance parameters listed in this specification are deemed as initial value measured under standard testing conditions.
- 使用环境温度-40°C~+85°C，湿度5%~85%RH。
Used in environment temperature -40°C~+85°C, humidity 5%~85%RH.
- 请避免安装在强磁场（变压器、磁铁周围）或发热物体附近。
Please avoid installing the device near high magnetic fields (eg.transformers or magnetics) or hot objects.
- 电寿命试验为阻性负载时的数值，应用在L/R≥1ms的感性负载回路时，请与感性负载并行采取浪涌吸收措施。未采取措施的情况下，可能会成电气寿命下降、发生切断不良。
The electrical life test is performed with resistive load. Therefore, please take surge absorption measures in parallel with inductive load when the device is applied to inductive load circuit with L/R≥1ms. Otherwise, the electrical life is likely to decline, resulting in poor cutting off.
- 应用在容性负载回路时，请注意采取预充等措施，建议接触器闭合压差控制在20V以内。如未采取措施，可能会造成触点粘连。
Measures including precharging etc. must be taken if the device is to be applied in capacitive load circuit. It is suggested that the differential pressure be controlled within 20V when the contactor is in closed position. Otherwise, it might lead to contact adhesion.
- 为抑制接触器线圈的反向电动势，建议加装非线性电阻（推荐使用可变电阻，最大能量耐量：1J以上；电压：额定电压的1.5~2倍）。若使二极管，会使接触器释放时间加长，会导致切断性能下降，请注意。
It is recommended to install a non-linear resistor (Variable resistors are preferred with over 1J maximum energy tolerance and 1.5-2 times of rated voltage) to suppress the reverse electromotive force generating from the contactor coil. Please be noted that the using of diode will prolong the release time of contactor, leading to degradation of cut-off performance.
- 请避免在引出端上粘附油脂等异物，建议使用10mm²以上规格导线，否则有可能造成引出端异常发热。
Please avoid adhering such foreign matters as grease etc. on the leading-out terminals. Over 10mm² conductors shall be used. Otherwise, it will casue abnormal heating of leading-out terminals.
- 请避免在使用或运输过程中发生撞击或跌落。为保持产品的性能，撞击或跌落后不建议继续使用。
Please avoid collision or falling during use or transportation. In order to maintain the performance of the product, it is not recommended to continue to use it after impact or fall.
- 接触器引出脚允许的插拔力为：(1)负载引出端49N，(2)线圈引出端49N。在超过范围的情况下，可能会造成破损。
The allowable plugging force for the terminal: (1)load terminal 49N, (2) coil terminal 49N. In the case of exceeding the range, damage may be occur when it is beyond the range.
- 螺钉安装时，螺纹咬合深度不能过浅，否则有可能导致滑牙松脱，建议咬合深度至少螺纹深度的2/3。
When installing the screws, the thread engagement depth shall not be too shallow, otherwise it may cause the sliding teeth to become loose. It is recommended that the engagement depth be at least 2/3 of the thread depth.
- PCB板焊接参数为：手工焊(380±20)°C，时间(3~5)s，波峰焊(260±5)°C，时间(3~5)s。
PCB welding parameters: manual welding (380±20)°C, time(3~5)s, wave soldering (260±5)°C, time (3~5)s.
- 为防止出现松动，接触器安装时请使用垫圈螺钉锁紧，各部位的螺钉锁紧扭矩请控制在以下范围：
To prevent looseness, the contactor shall be locked with washer screws during installation, and the screw locking torque of each part shall be controlled within the following range:

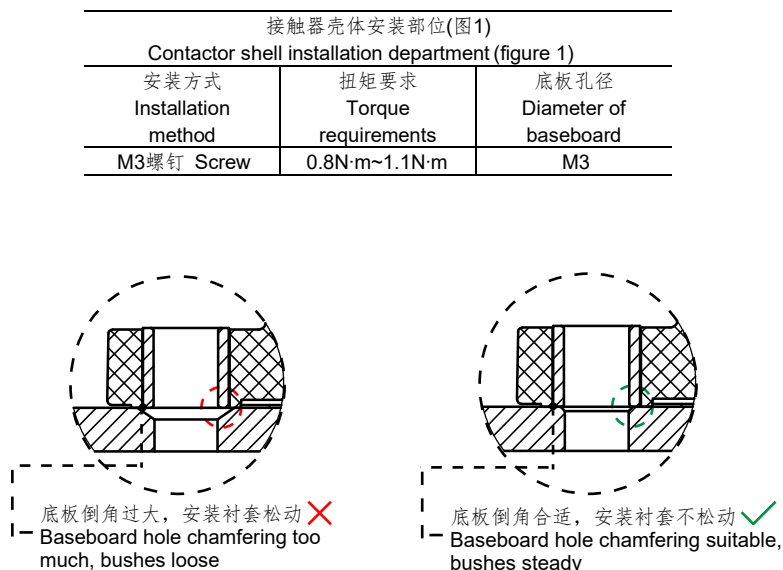

图1(Fig1)